

*訂購時請將圖面連同訂單一併回傳。 *Please send back with order while ordering.

客戶確認 Confirmed

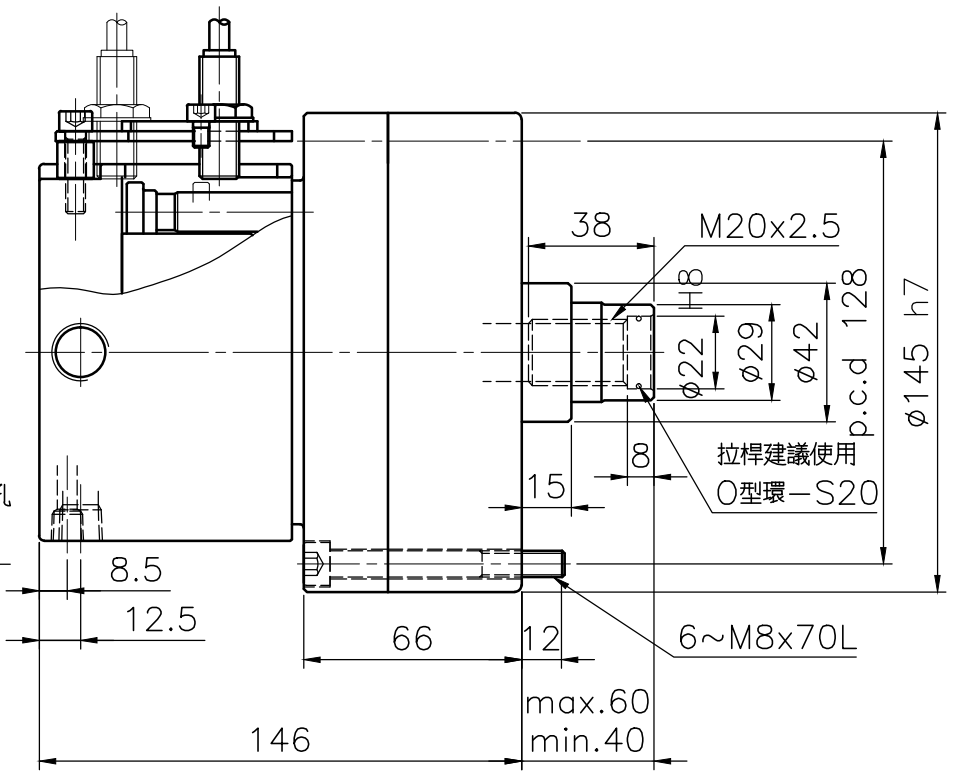
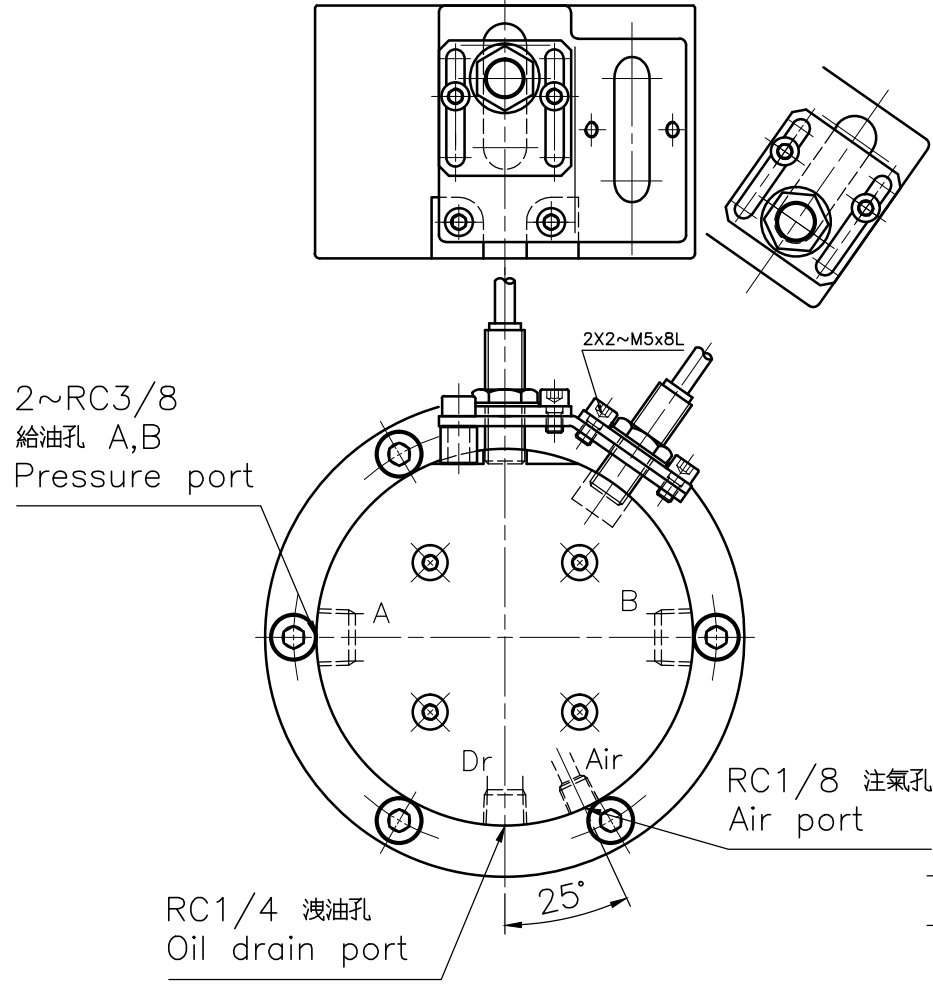

名稱 Name	精短整合型注氣迴轉油壓缸 COMPACT STYLE HYDRAULIC CYLINDER	
規格 Spec. 型號 Model	RE-A110	
活 塞 面 積 Eff. piston area	伸側 Extend cm ²	91.2
	拉側 Retract cm ²	87.9
行程 Piston stroke mm		20
最高使用迴轉數 Max. speed r.p.m.		6000
最高使用壓力 Max. pressure kgf/cm ²		40
I Moment of inertia	kgf m ²	0.02
重量 Weight kgs		6.9
總洩漏量 otal oil leakage liter/min		0.8

注氣部最高使用壓力為8kgf/cm²
Air connection max. pressure 8kgf/cm²

- 洩油孔配管務必單獨接回油槽，以避免產生背壓。
- The drain port should be independently connected to oil tank to avoid back pressure.

*為確保產品品質日益精進，敝公司擁有設計變更之權。 *Subject to technical changes.

AUTOGrip AUTOGRIP MACHINERY CO., LTD.