

*訂購時請將圖面連同訂單一併回傳。 *Please send back with order while ordering.

客戶確認 Confirmed

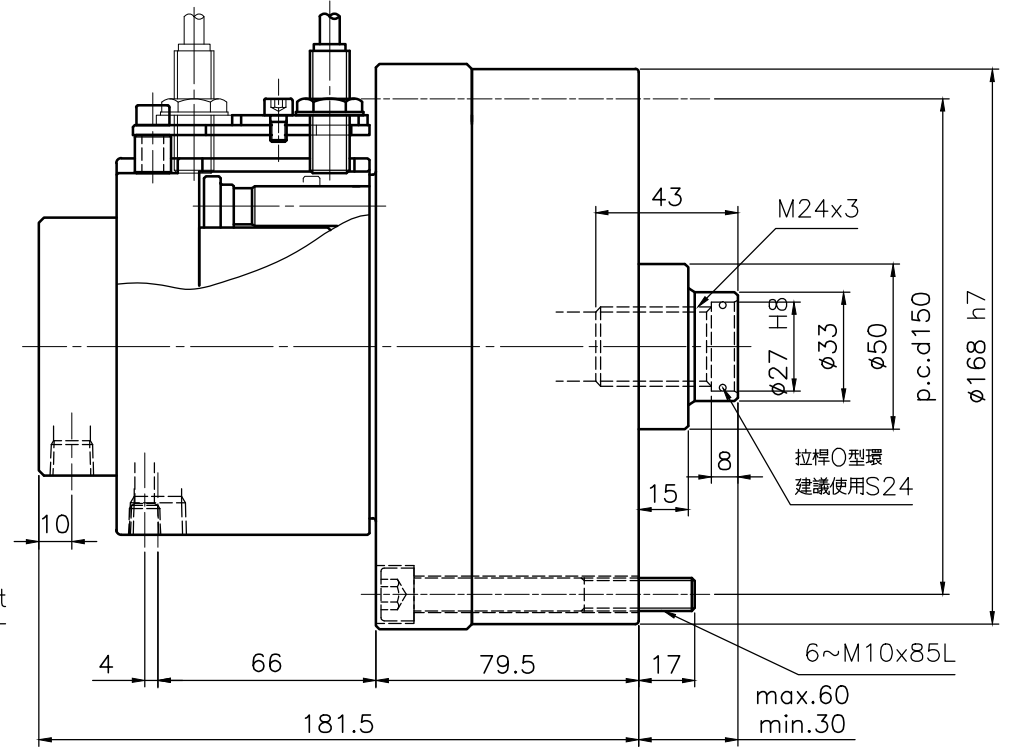
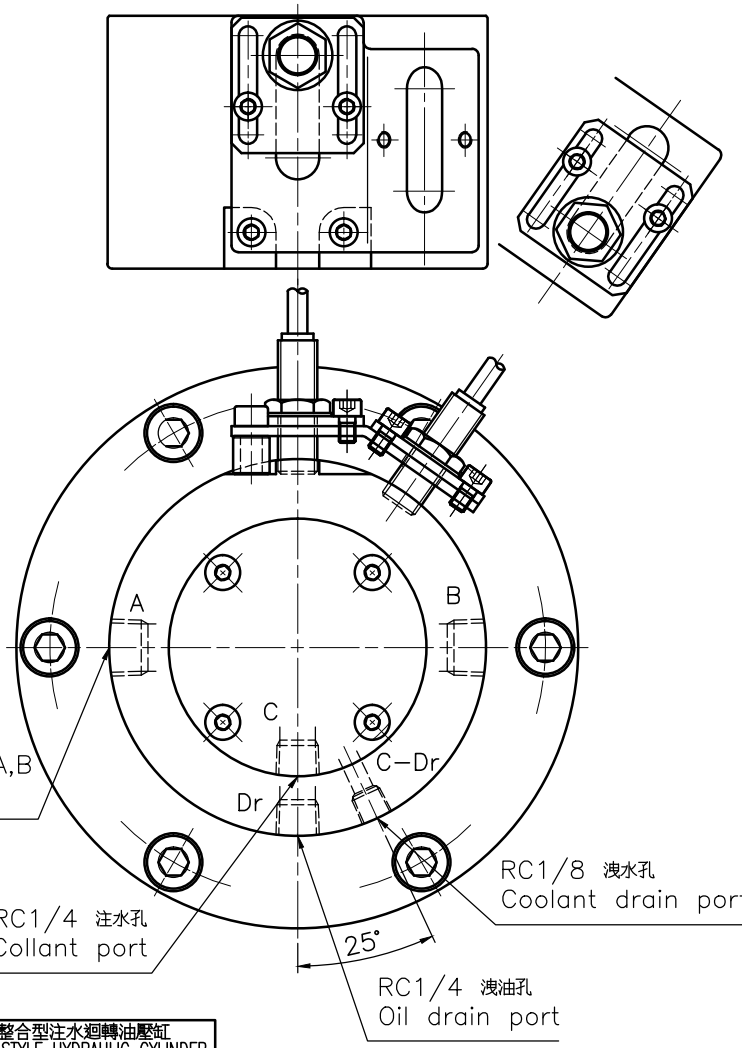

名稱 Name	精短整合型注水迴轉油壓缸 COMPACT STYLE HYDRAULIC CYLINDER	
規格 Spec. 型號 Model	RE-L130	
活 塞 面 積	伸側 Extend cm ²	128.9
Eff. piston area	拉側 Retract cm ²	123.1
行程	Piston stroke mm	30
最高使用迴轉數	Max. speed r.p.m.	6000
最高使用壓力	Max. pressure kgf/cm ²	40
I	Moment of inertia kgf m ²	0.03
重量	Weight kgs	9.5
總洩漏量	otal oil leakage liter/min	

- 洩油孔配管務必單獨接回油槽，以避免產生背壓。
 - The drain port should be independently connected to oil tank to avoid back pressure.
 - 注水部無液體通過時，請勿運轉。
 - The rotary cylinder should not run without liquid through coolant port.
- *為確保產品品質日益精進，敝公司擁有設計變更之權。 *Subject to technical changes.